



US 20040134785A1

(19) **United States**

(12) **Patent Application Publication**

Gay et al.

(10) **Pub. No.: US 2004/0134785 A1**

(43) **Pub. Date: Jul. 15, 2004**

(54) **ADVANCED HIGH-THROUGHPUT
ELECTROREFINER DESIGN**

(52) **U.S. Cl. 205/46**

(75) **Inventors: Eddie C. Gay, Park Forest, IL (US);
James L. Willit, Batavia, IL (US);
Donald E. Preuss, Hinsdale, IL (US)**

(57) **ABSTRACT**

Correspondence Address:

**Harry M. Levy, Esq.
Emrich & Dithmar
Suite 3000
300 South Wacker Drive
Chicago, IL 60606 (US)**

A nuclear fuel electrorefiner for recovering uranium from nuclear material containing uranium. A cylindrical vessel with having a longitudinal axis has a product collector movable axially of the vessel. Circular cathodes extend axially of and radially spaced inwardly of the vessel with a plurality of generally polyhedron-shaped anode baskets having at least one face aligned with a radius of said vessel and circumferentially spaced from adjacent anode baskets and concentric with respect to the cathodes in the vessel. A plurality of axially extending metal rods are insulated from and placed between the anode baskets. Mechanism outside of the vessel rotate the anode baskets and the metal rods with respect to the cathodes, and an electrical power supply in selective electrical communication with said cathode and said anode baskets and said metal rods to cause uranium values to move between the and when current flow is in a first direction uranium values in said anode baskets and the metal rods to the cathodes.

(73) **Assignee: The University of Chicago, Chicago, IL**

(21) **Appl. No.: 10/339,955**

(22) **Filed: Jan. 9, 2003**

Publication Classification

(51) **Int. Cl.⁷ C25C 3/34**

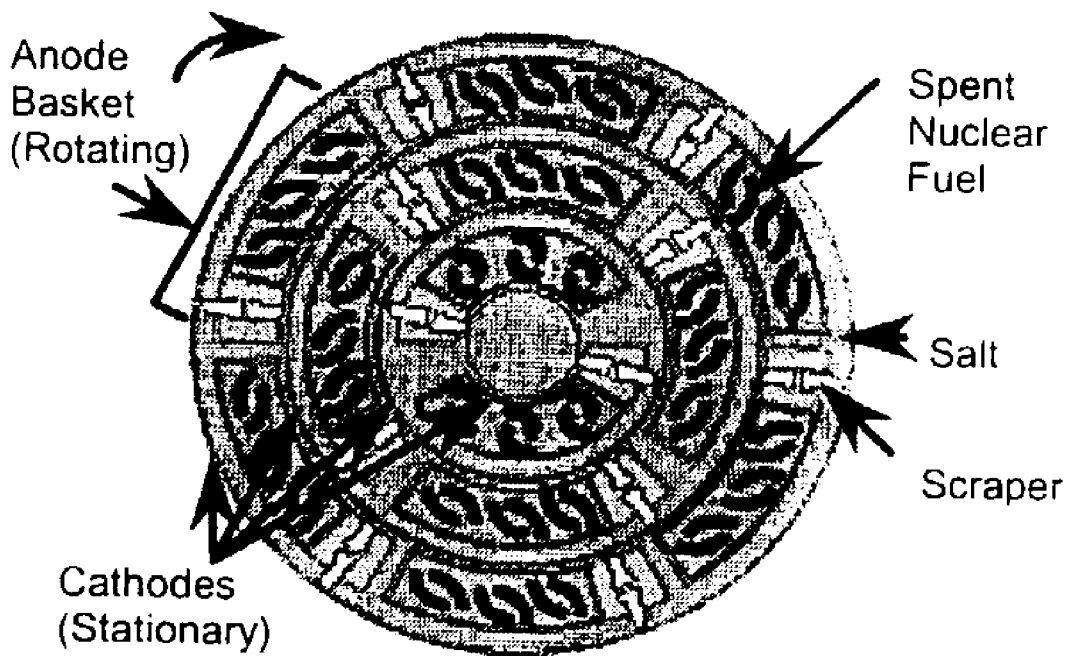

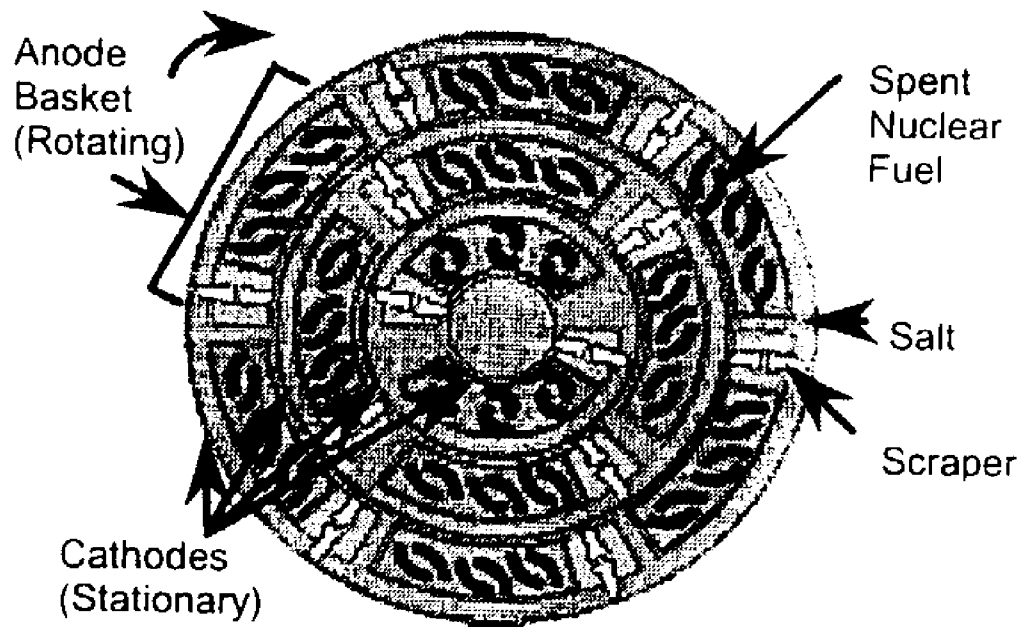

FIG. 1

PCR HTER - Full Assembly

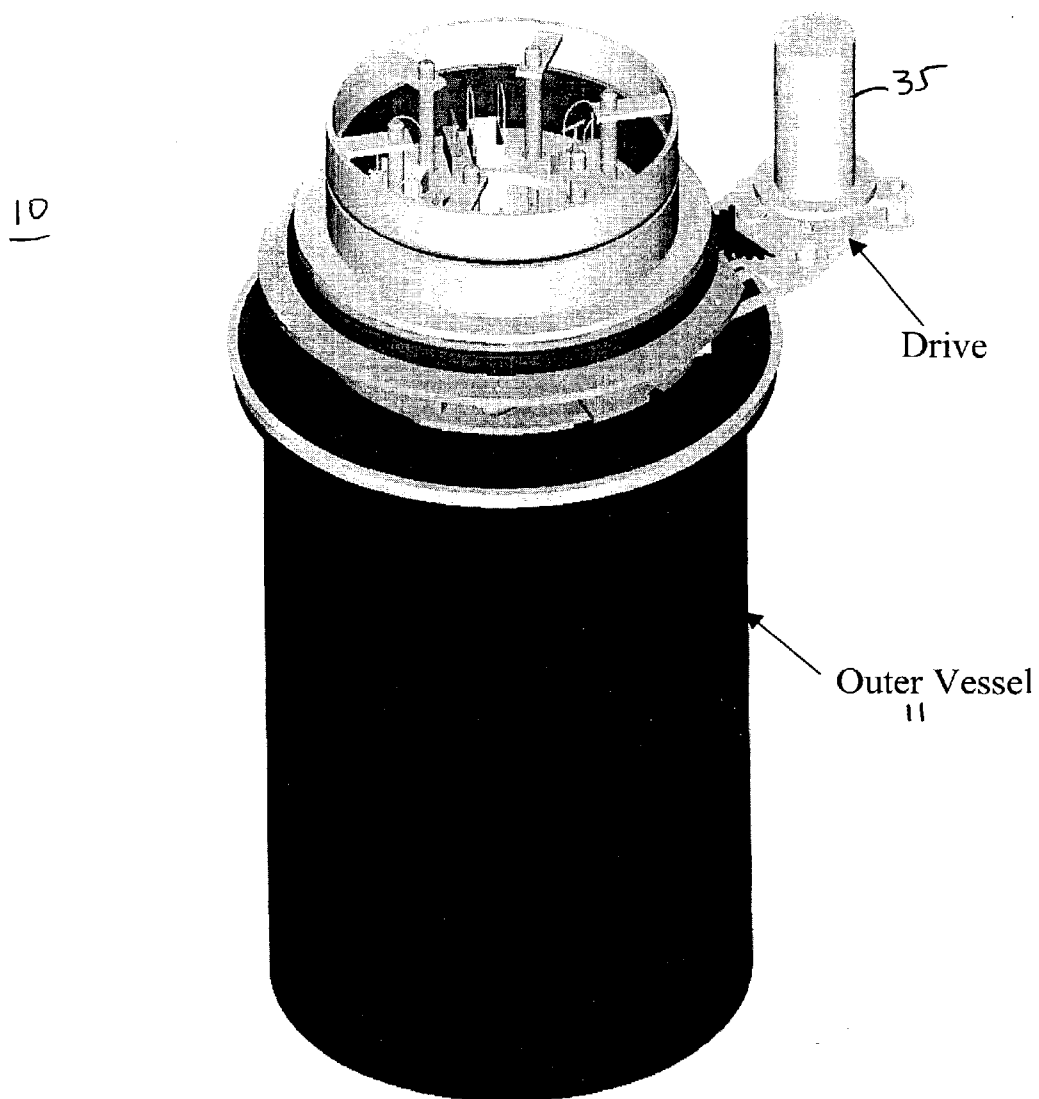

FIG. 2

PCR HTER - Close-up of Top

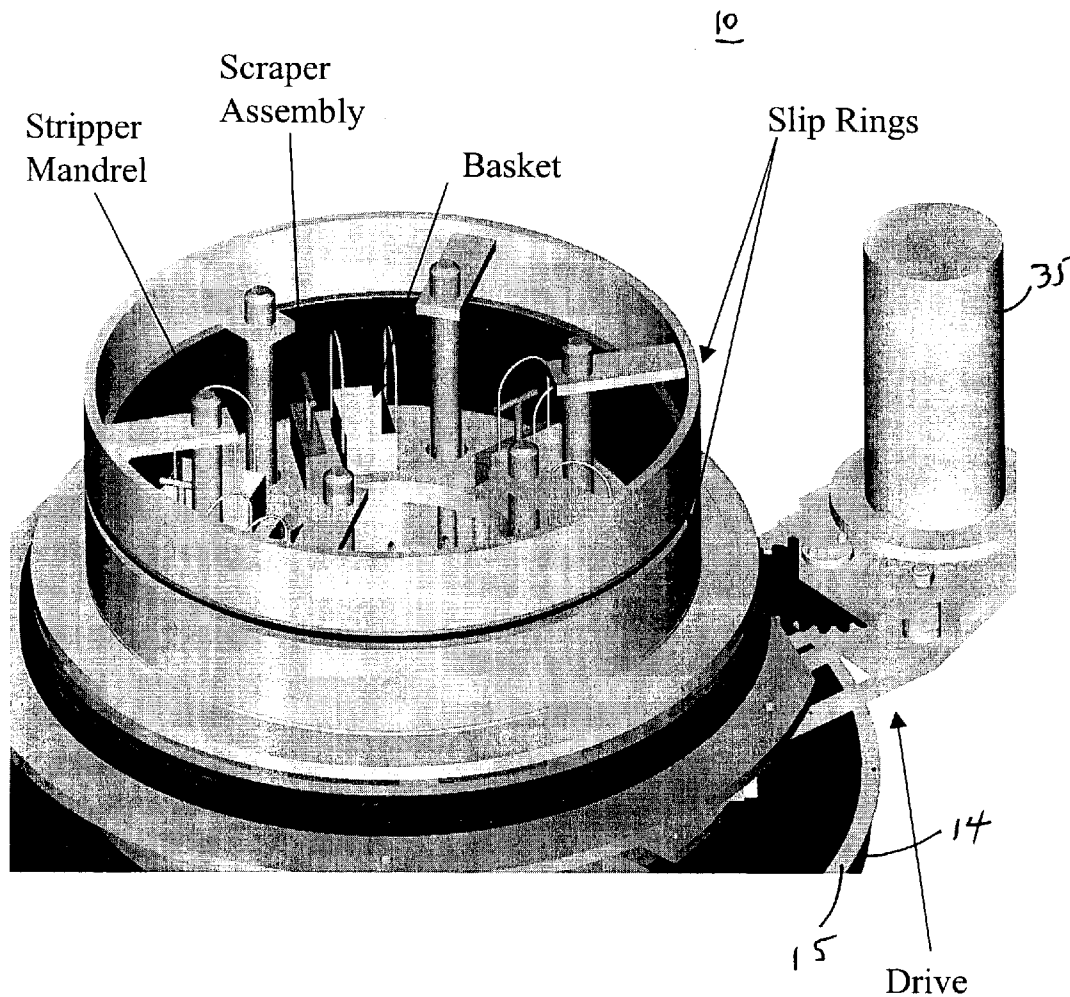

FIG. 3

PCR HTER - Well & Heaters Removed

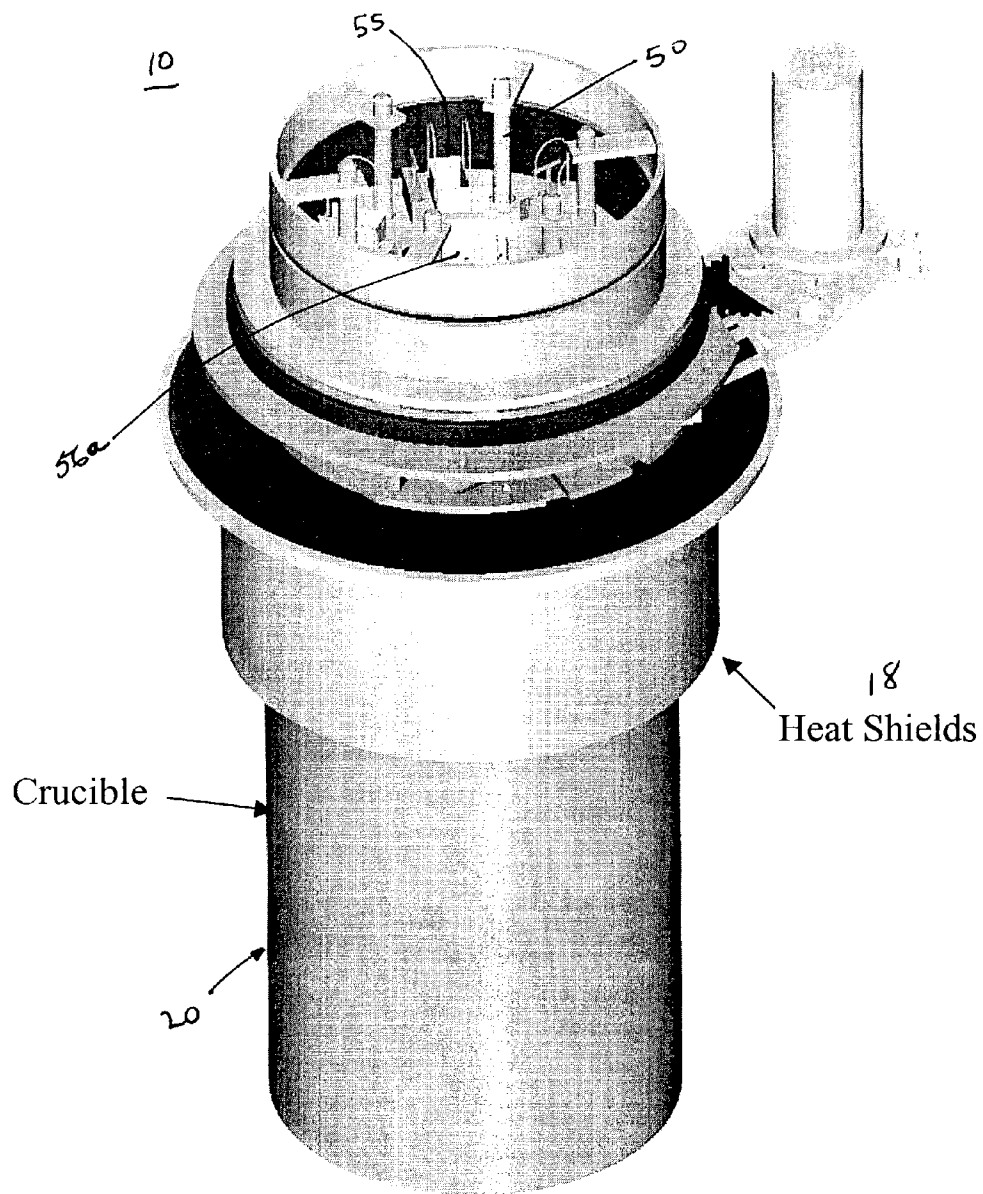

FIG. 4

PCR HTER - Crucible Removed

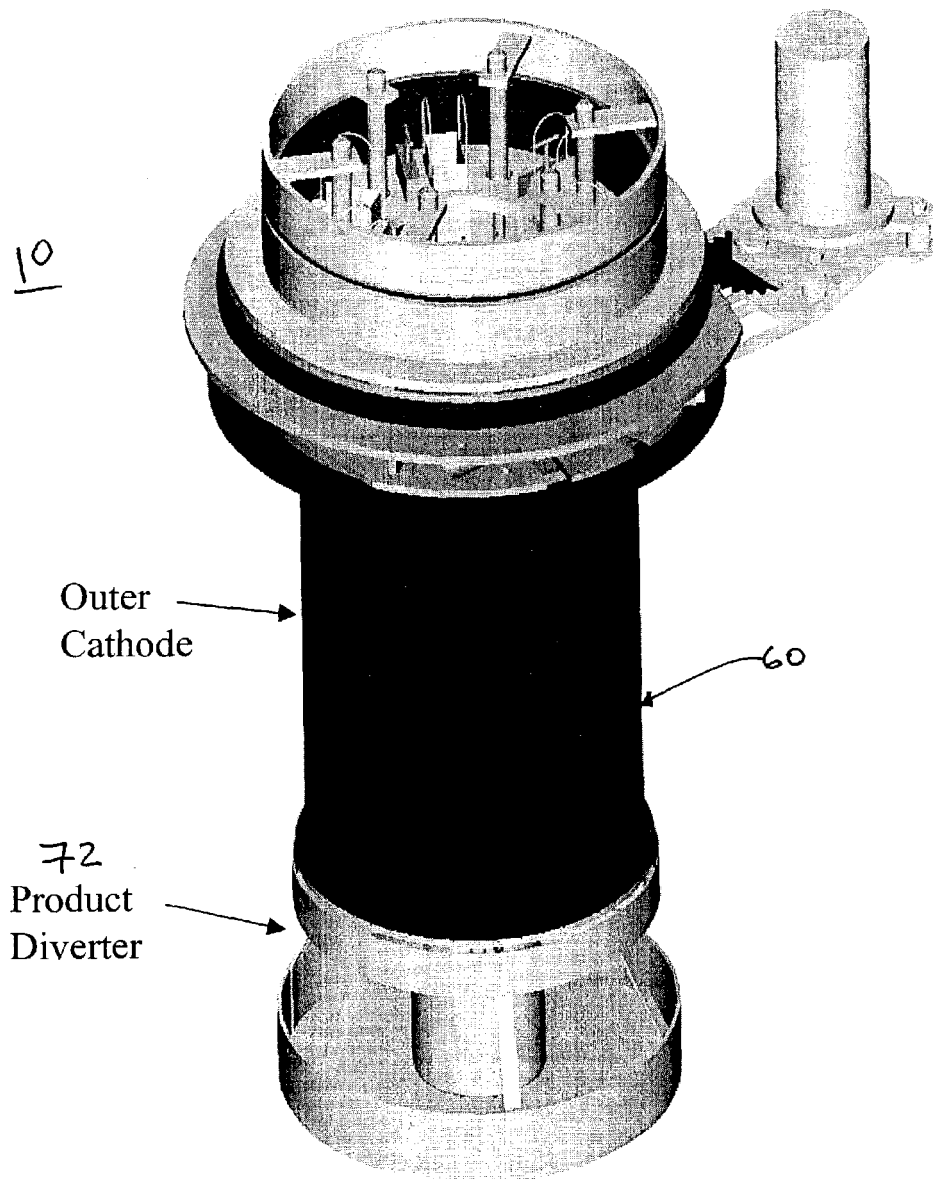

FIG. 5

PCR HTER - Outer Cathode Removed

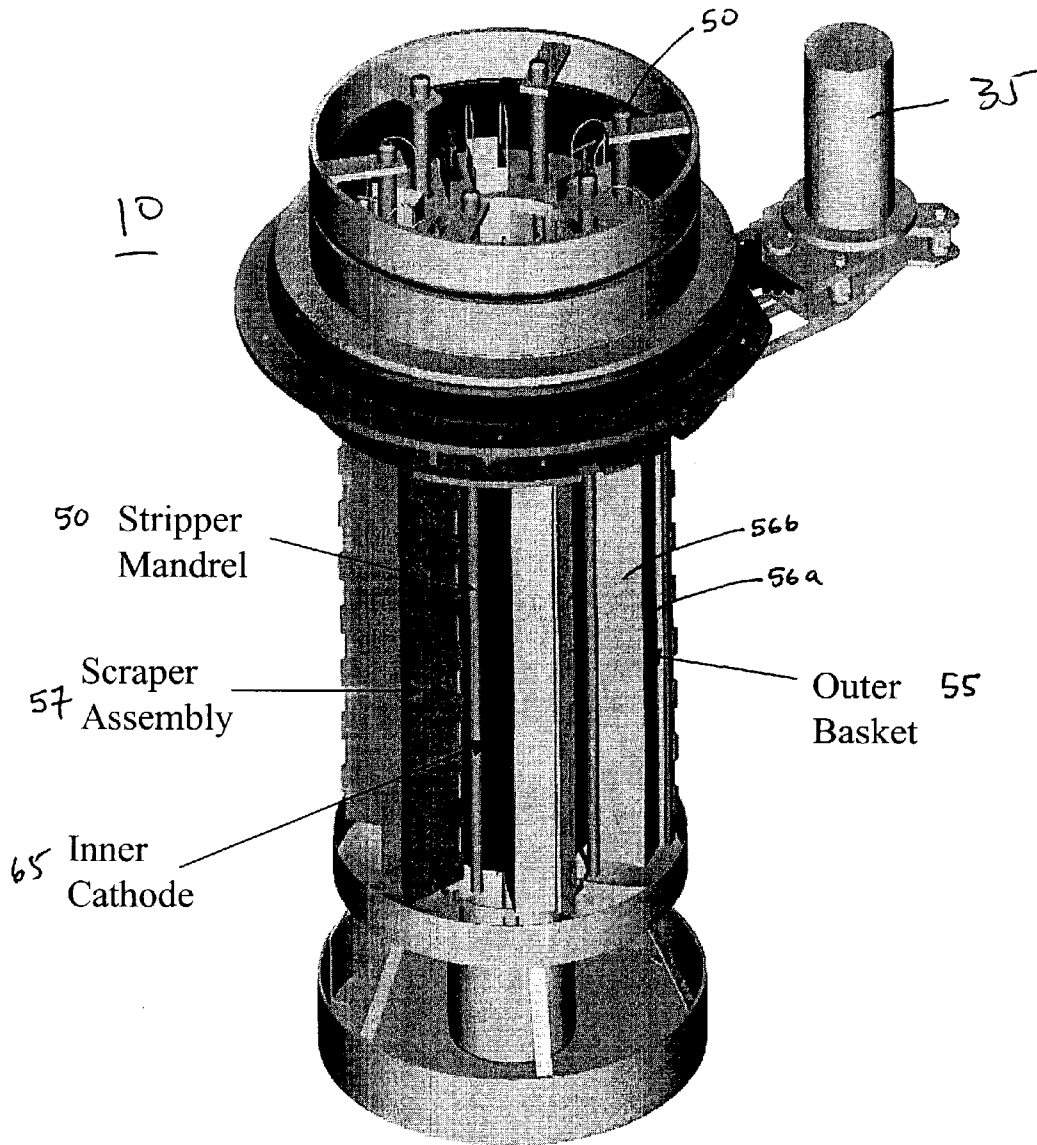

FIG. 6

Anode Basket Removal/Insertion

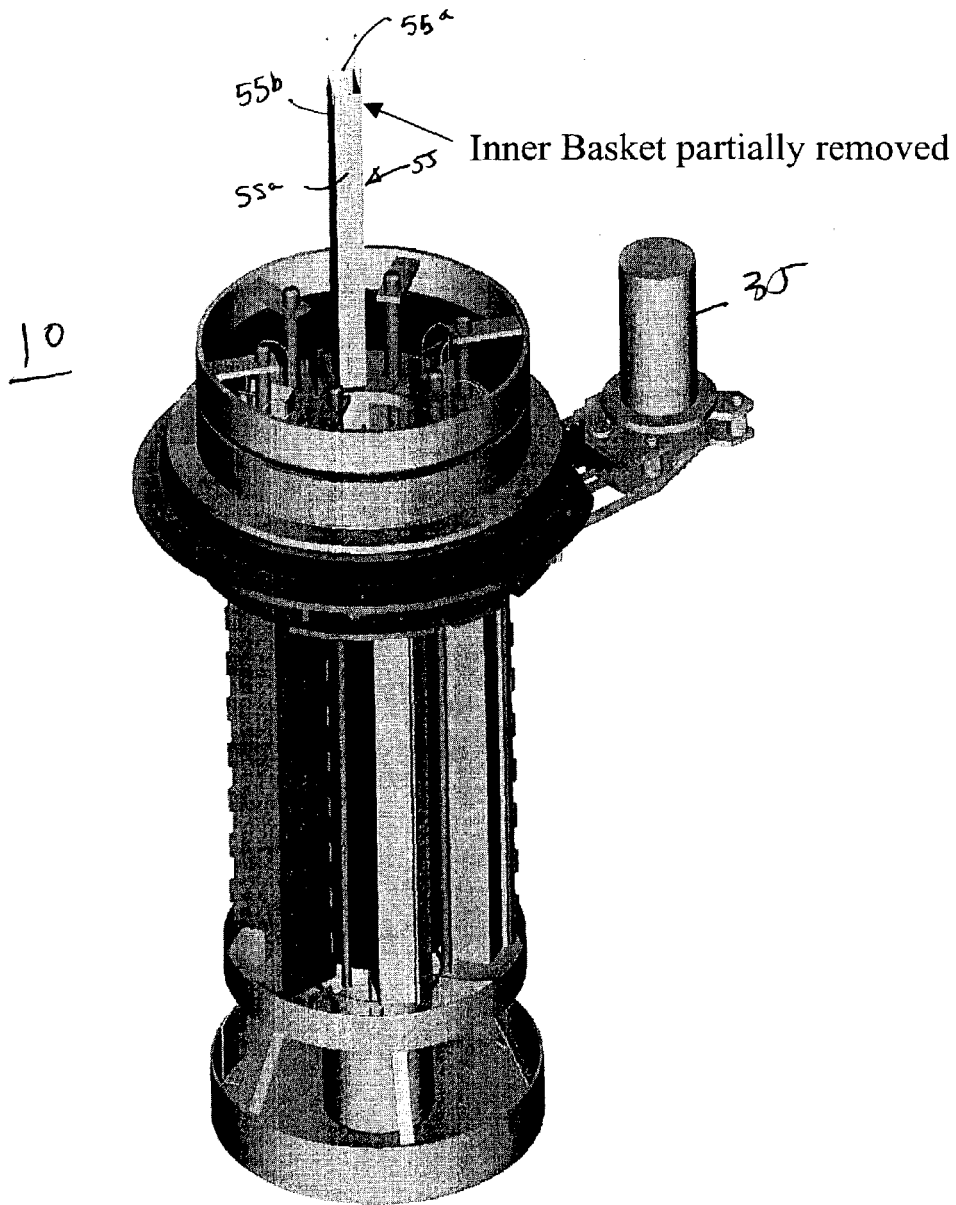

FIG. 7

Scraper Assembly Removal/Insertion

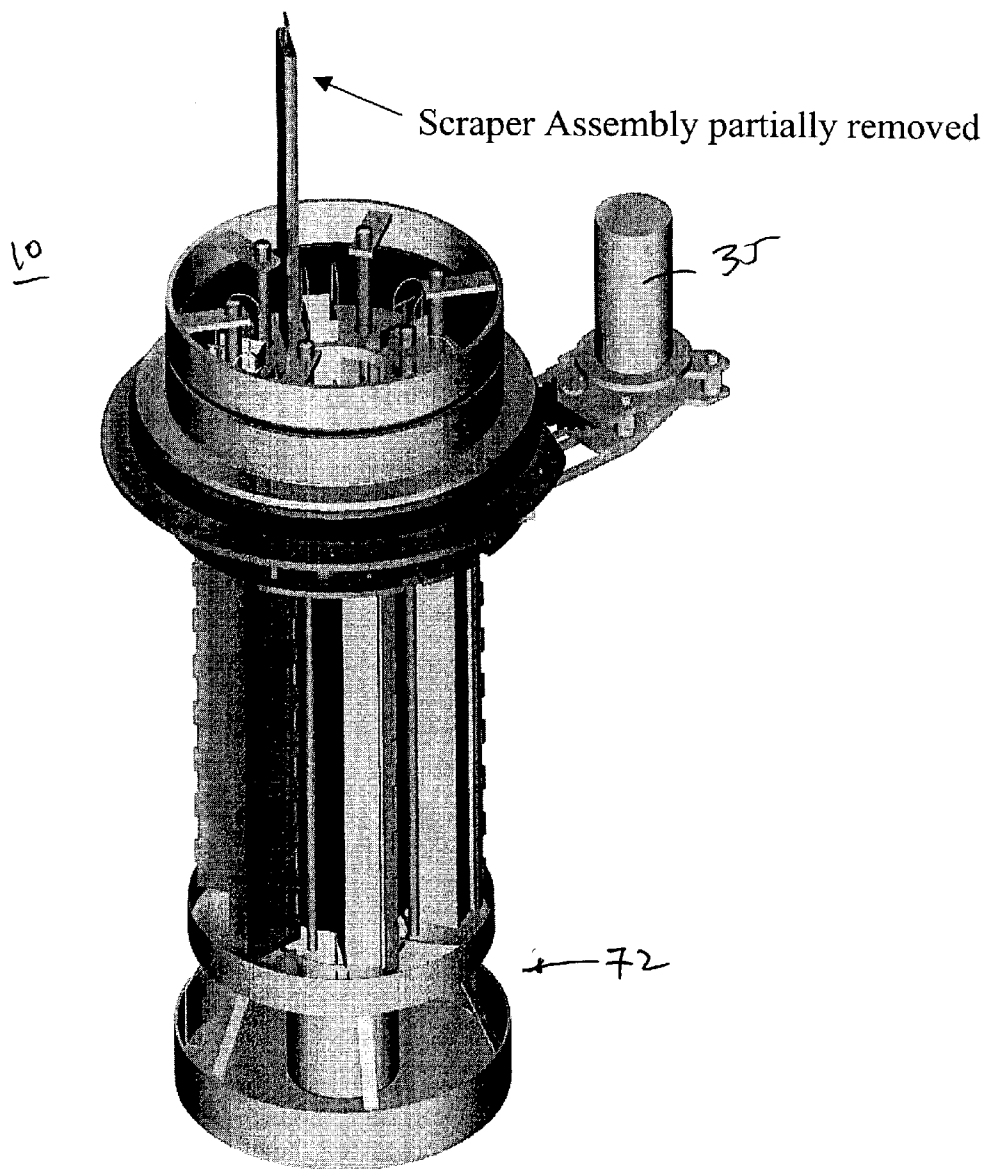

FIG. 8

PCR HTER - Close-up of Bottom

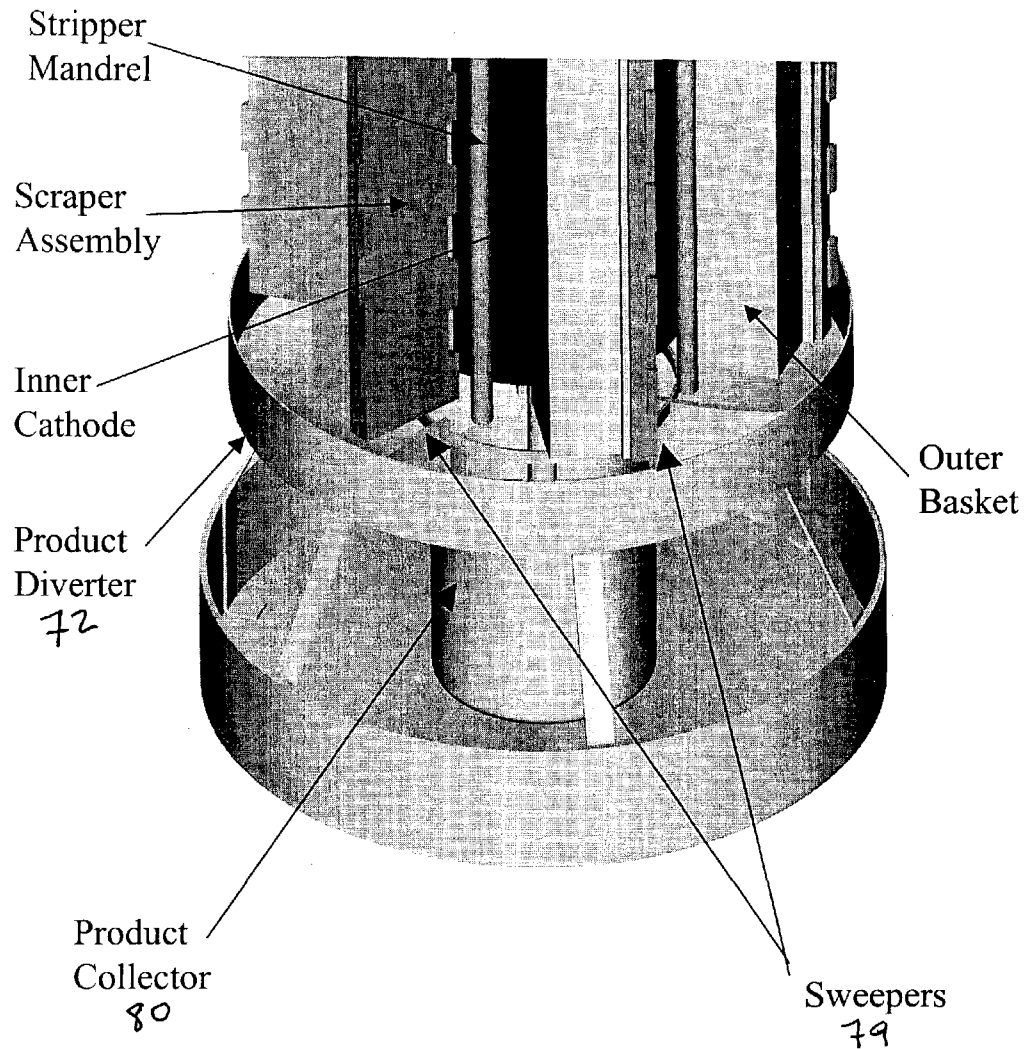

FIG. 9

Diverter, Sweeper & Product Collector

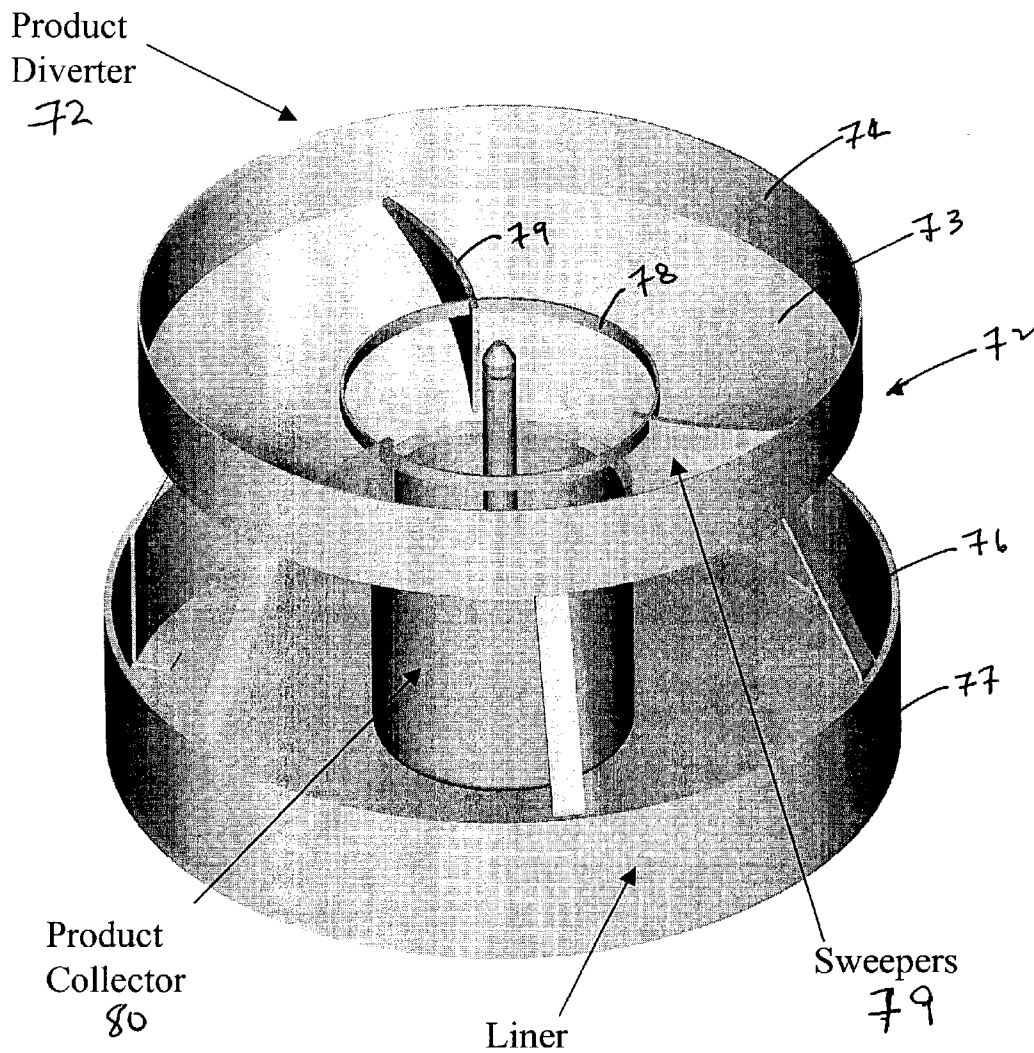

FIG. 10

Center Removal of Product Collector

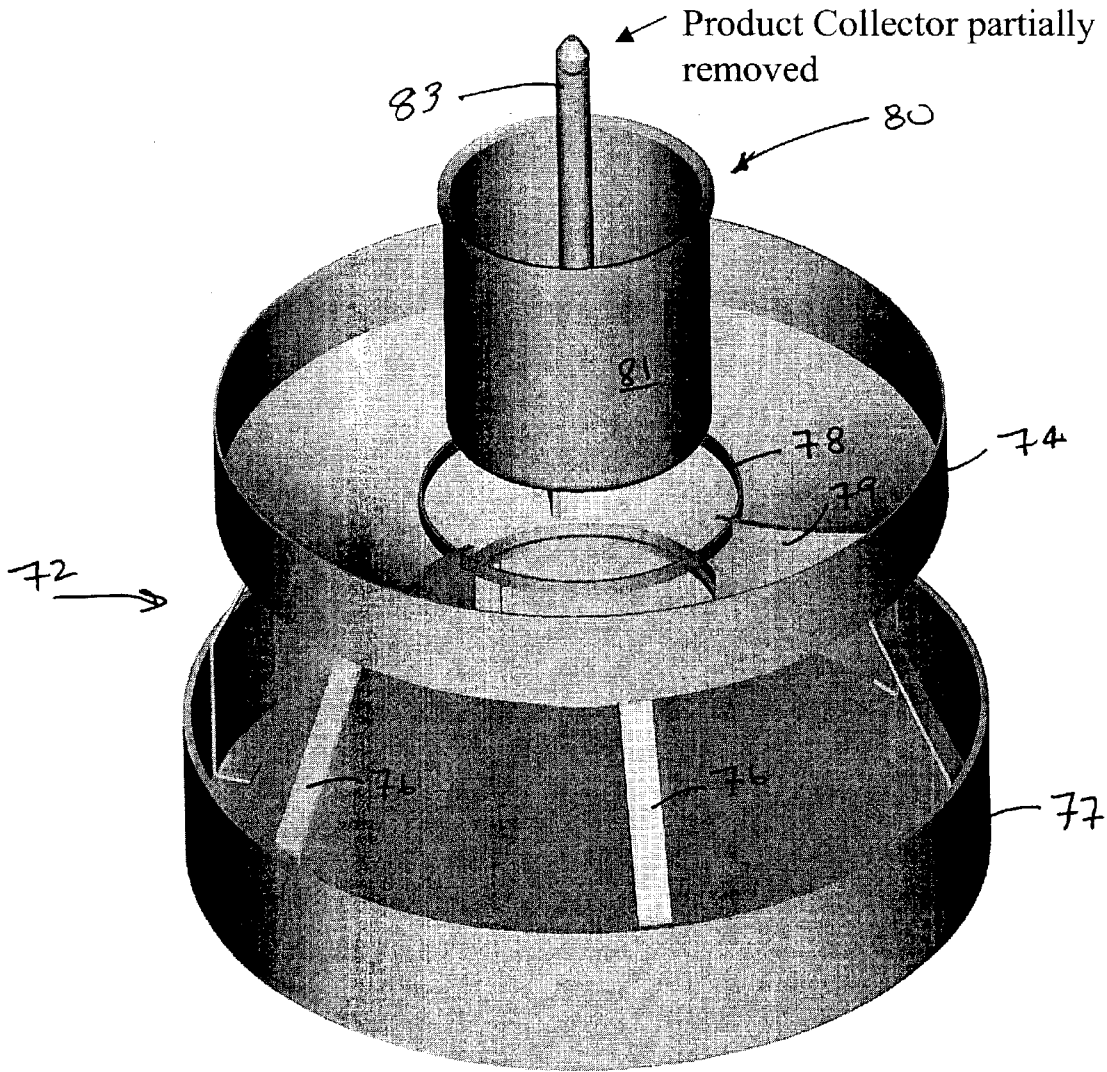
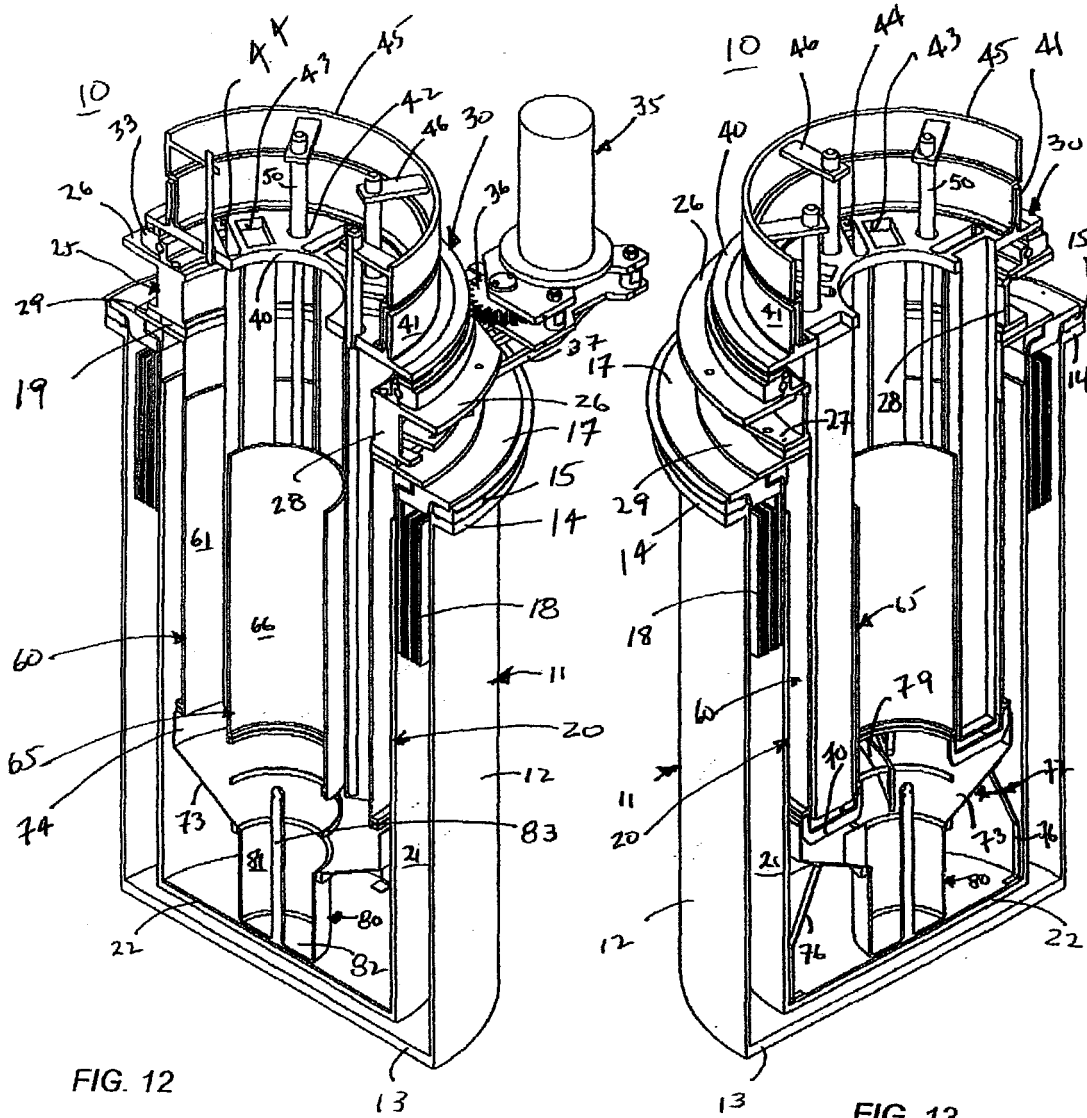

FIG. 11



ADVANCED HIGH-THROUGHPUT ELECTROREFINER DESIGN

[0001] The United States Government has rights in this invention pursuant to Contract No. W-31-109-ENG-38 between the U.S. Department of Energy (DOE) and The University of Chicago representing Argonne National Laboratory.

FIELD OF INVENTION

Background of the Invention

[0002] Electrorefining is a metallurgical separation technique that has been used to recover uranium from fission products and other components of spent fuel from the Experimental Breeder Reactor-II (EBR-II), as well as to purify impure plutonium metal. The technique is well suited to this application because the separation is based on changes in oxidation state and is accomplished by the addition or removal of electrons at electrodes rather than the use of chemical oxidizing or reducing agents, which can significantly increase the volume of waste generated.

[0003] For the last six years, personnel at Argonne National Laboratory (ANL) have mounted a significant effort to increase the throughput of this process as it is applied to the treatment of spent EBR-II fuel. In that time ANL personnel have moved from a small prototype device to a working unit that was demonstrated successfully at a throughput of 150 kg uranium/month with actual spent fuel in the Fuel Cycle Facility at ANL-West. The throughput still needs to be substantially increased, however, to handle the large inventory of EBR-II blanket fuel and other spent metal fuels at DOE sites. The basic electrochemistry of the process is now well understood and optimized. Consequently, increasing the throughput has focused primarily on improving the engineering of the process.

[0004] In the high-throughput electrorefiner design, uranium was loaded into anode baskets that rotated in a channel between cathode tubes. The anode assembly and the cathode tubes were submersed in a molten LiCl-KCl eutectic. The salt also contained 5 to 7 wt. % uranium cations. Uranium and the elements in the fuel that are less noble than uranium were oxidized at the anode and formed cationic species that dissolved in the molten salt. Uranium cations were then reduced at the cathode, and the reduced uranium metal deposited on the cathode surface. Scrapers mounted on the rotating anode basket assembly dislodged the electrodeposited uranium, which fell to the bottom of the unit where it was collected.

[0005] The schematic of FIG. 1 presents a cross-sectional rendering of the prior art high-throughput concept. FIG. 1 shows 12 anode baskets with attached scrapers in the unit. Four cathode tubes form three channels within which the anode baskets rotate. After being scraped off the cathode tubes, the uranium product is collected in a basket attached to the bottom of the outer cathode tube. With a 10-in. (25-cm) diameter module, uranium can be removed from spent EBR-II fuel at an average rate of nearly half a kilogram per hour. In the Fuel Cycle Facility at ANL-West, four of these units are operated in a single process vessel. One of the key steps required in the opening profile is a periodic reversal of the current to remove a dense layer of

uranium that builds up on the surface of the cathode and is not dislodged by the scrapers.

SUMMARY OF THE INVENTION

[0006] Accordingly, it is an object of the present invention to provide next-generation high-throughput electrorefiner that is capable of treating as much as 20 metric tons of uranium per year.

[0007] Another object of the invention is to provide an electrorefiner with a peripherally driven anode assembly, independent removal of the product collector, and electrically isolated stripper rods located between the anode baskets.

[0008] Yet another object of the present invention is to provide a nuclear fuel electrorefiner for recovering uranium from nuclear material containing uranium, comprising a cylindrical vessel having a longitudinal axis containing at the bottom thereof, a product collector movable axially of the cylindrical vessel, at least one cathode generally circular in horizontal cross section extending axially of and radially spaced inwardly of the vessel, a plurality of generally polyhedron-shaped anode baskets extending axially of the vessel, each anode basket having at least one face aligned with a radius of the vessel and circumferentially spaced from adjacent anode baskets and concentric with respect to the cathode, mechanism outside of the vessel rotating the generally polyhedron-shaped anode baskets with respect to the cathode, and an electrical power supply in selective electrical communication with the cathode and the anode baskets for causing uranium values in the anode baskets in the presence of a molten electrolyte containing uranium cations to move between the anode baskets and the cathode where uranium values are reduced to uranium metal and thereafter uranium metal is transported from the cathode to the product collector axially removable from the vessel without removing either the anode baskets or the cathode.

[0009] Still another object of the present invention is to provide a nuclear fuel electrorefiner of the type set forth in which a plurality of axially extending metal rods are spaced circumferentially about the longitudinal axis of the vessel and are electrically insulated from and positioned between at least some of the anode baskets.

[0010] Still another object of the present invention is to provide a nuclear electrorefiner of the type set forth in which there are a plurality of concentric radially spaced apart cathodes and a plurality of anode baskets arranged in the annular space(s) or channel(s) between the cathodes.

BRIEF DESCRIPTION OF THE DRAWINGS

[0011] The invention consists of certain novel features and a combination of parts hereinafter fully described, illustrated in the accompanying drawings, and particularly pointed out in the appended claims, it being understood that various changes in the details may be made without departing from the spirit, or sacrificing any of the advantages of the present invention.

[0012] FIG. 1 is a cross-sectional view of a representative prior art high-throughput electrorefiner design known as the Mark V operated at ANL-West;

[0013] FIG. 2 is a peripheral drive center removable (PCR) electrorefiner full assembly;

[0014] FIG. 3 is a PCR electrorefiner full assembly illustrated in FIG. 2 showing an enlarged view of the top;

[0015] FIG. 4 is a PCR electrorefiner full assembly illustrated in FIG. 2 with the well and heaters removed;

[0016] FIG. 5 is a PCR electrorefiner full assembly illustrated in FIG. 2 with the crucible removed;

[0017] FIG. 6 is a PCR electrorefiner full assembly illustrated in FIG. 2 with the outer cathode removed;

[0018] FIG. 7 is a PCR electrorefiner full assembly illustrated in FIG. 2, showing the removal/insertion of the anode baskets;

[0019] FIG. 8 is a PCR electrorefiner full assembly illustrated in FIG. 2 showing the removal/insertion of the scraper assembly;

[0020] FIG. 9 is a PCR electrorefiner full assembly illustrated in FIG. 2 showing a close-up of the bottom;

[0021] FIG. 10 is a PCR electrorefiner full assembly illustrated in FIG. 2 showing the diverter, sweeper and product collector;

[0022] FIG. 11 is a PCR electrorefiner full assembly illustrated in FIG. 2 showing the center removal of the product collector;

[0023] FIG. 12 is a cross-sectional view of a PCR assembly; and

[0024] FIG. 13 is a cross-sectional view of the PCR assembly of FIG. 12 taken along a different radial line.

DESCRIPTION OF THE PREFERRED EMBODIMENTS

[0025] The present invention remedies several design inadequacies of the Mark V electrorefiner. Although the PCR design of the present invention includes concentric cathode tubes as well as cathode scrapers and anode baskets in the gap or annular space or channel between the concentric cathode tubes, the present invention is a peripheral drive device in which the center portion of the refiner is free permitting anodes, cathodes and most importantly product to be removed axially independently of each other. Previous designs used a central drive shaft to rotate a plate from which the anode baskets were suspended. In the present design the baskets although suspended from a rotating plate similar to the Mark V electrorefiner is driven by a drive motor positioned outside the vessel so as to free the interior thereof. This inventive design makes possible the center removal of the electrorefined uranium product, unlike the Mark V electrorefiner which requires both the anode and cathode components to be removed prior to removal of the product.

[0026] Another important feature of the present invention is that although cathode scrapers are provided, their use is reduced and in fact some cases may be obviated entirely. In the present design, the anode baskets because of their configuration produce a higher current density close to the cathode wall and scrape uranium product deposited on the cathode into the product collector at the bottom of the unit. In addition, the inclusion of stripper mandrels rods which are electrically insulated from the anode basket(s) is also an important feature. During operation of the Mark V electrorefiner it was found that a hard uranium dendritic coating formed on the cathodes and the only way to remove it was

to reverse the current to the vessel thereby electrolytically removing the uranium from the cathode while simultaneously plating the uranium values on the outside of the anode baskets. While effective in removing the hard or dense uranium dendritic coating on the cathodes, this required the outside coating of uranium on the anode baskets to be removed from the anode baskets prior to removal of uranium from the chopped fuel elements inside the anode baskets after current had been reversed once again. This entire reversal requirement slowed down the electrorefining process to a significant extent. With the use of stripper mandrels as hereinafter described, when the current is reversed, uranium is principally plated onto the stripper mandrels as well as on the anode baskets, thereby reducing the amount of uranium which must be removed from the outside of the anode baskets before the uranium values inside the anode baskets are transported to the cathodes.

[0027] It is believed that use of the hereinafter described invention will be able to achieve a 450 kpm throughput. Tables 1 and 2 includes calculations based on the hereinafter described invention for both one channel and two channel PCRs. Two channel PCRs relate to three cathodes and two annular channels of anode baskets with stripper mandrels positioned between each of the anode baskets.

TABLE 1

Throughput calculations - Basis			
1-Channel PCR (25" diameter)	cathode	anode	stripper mandrel
Electrode Area, cm ²	13406	7392	4750
sticking coefficient	0.8	N/A	0.5
deposition current density, A/cm ²	0.135	0.15	0.15
stripping current density, A/cm ²	0.102	0	0.287
2-Channel PCR (36" diameter)	cathode	anode	stripper mandrel
Electrode Area, cm ²	26126	19712	11260
sticking coefficient	0.8	N/A	0.5
deposition current density, A/cm ²	0.178	0.15	0.15
stripping current density, A/cm ²	0.107	0	0.249

[0028]

TABLE 2

Operational Cycle and Throughput			
	A-h	I/A	time/h
1-Channel PCR			
Deposition	500	1821.3	0.27
Rods	200	712.5	0.28
Baskets	300	11.08.8	0.27
Strip	400	1362	0.29
Wash			0.10
2-Channel PCR			
Deposition	500	4646	0.11
Rods	200	1689	0.12
Baskets	300	2957	0.10
Strip	400	2804	0.14
Wash			0.10

peak throughput = 1112 g/hr
avg monthly throughput = 450 kg/mo

peak throughput = 2077 g/hr
avg monthly throughput = 841 kg/mo

[0029] Referring now to the drawings, there is disclosed a peripheral drive center removal PCR electrorefiner **10** which has an outer vessel **11** cylindrical in design having a cylindrical wall **12** and a horizontal bottom **13**. The cylindrical wall **12** ends in an outwardly extending flange **14** at the top of the outer vessel **11**. An insulator ring **15** is positioned on top of the flange **14** and receives or carries a plate **17** which is normally Z-shaped cross section as is seen in the left hand portion of **FIG. 12**. Heater shields **18** are suspended from the plate **17**, and there is also provided an insulator ring **19** as seen in **FIG. 12**.

[0030] A cylindrical crucible **20** is positioned inside the outer vessel **11** and has a vertically extending cylindrical wall **21** and a bottom **22**. The double wall nature of the crucible **20** and the outer vessel **11** are safety features. An annular fixture **25** sits on top of the insulating ring **19** and includes a top flange **26** and a bottom flange **27** interconnected by a vertically extending bight **28**. An outer ring **29** provides support for a top plate **30** and includes a gear ring **33** on the outer periphery thereof which is engaged by a peripheral drive motor **35** having an output gear **36**. A mounting structure **37** mounts the peripheral drive motor **35** to the fixture **25**.

[0031] The top plate **30** has a horizontal flange **40** connected to an upstanding vertical flange **41**, the horizontal flange **40** being provided with spaced apart circular apertures **42**, spaced apart rectangular apertures **43** and spaced apart rectangular apertures **44**, the apertures **43** being wider than the apertures **44**, both having the longer dimension positioned radially of the vessel **11**.

[0032] A slip ring **45** is mounted interior of the flange **41** and is electrically insulated therefrom and carries a plurality of horizontally extending supports from which extend a plurality of mandrel rods **50**, each of the mandrel rods **50** being electrically insulated from the horizontal flange **40** of the top plate **30**.

[0033] A plurality of axially extending circumferentially spaced apart anode baskets **55** are positioned within the apertures **43**. Each anode basket **55** as seen in **FIG. 7** is polyhedron-shaped and may be of any convenient design, such as pentahedron or hexahedron. In the preferred embodiment, the anode basket **55** is a hexahedron with the two faces extending radially of the vessel **11** being longer than the two opposed faces extending perpendicularly to the radial faces. More particularly, as seen in **FIG. 7**, each anode basket **55** includes opposed faces **55(a)** which are smaller in dimension than opposed faces **55(b)**, the faces **55(b)** being positioned along the radius of the cylindrical vessel **11**. As is well known in the art, the anode baskets **55** are perforated and may be provided with screens to retain fines within the anode basket during the electrorefining process.

[0034] Scraper assemblies **57** are positioned preferably intermediate each anode basket **55** and each mandrel rod **50**. The scraper assemblies **57** extend axially of the vessel **11** the length of the cathodes **60**, **65** and are standard in the art. In the inventive PCR **10**, the scraper assemblies **57** may or may not be required depending on the efficiency of the mandrel rods **50** and the anode baskets **55** scraping deposited uranium from the cathodes, as will be described. There are provided two cathodes, an outer cathode **60** having a cylindrical wall **61** and an inner cathode **65** having a cylindrical wall **66**. Cathodes **60**, **65** are supported at the bottom of the

vessel **11** by means of a cathode support **70**, generally U-shaped in vertical cross section to support the outer and inner cathode **60** and **65** respectively, as best seen in **FIG. 13**.

[0035] As illustrated in **FIGS. 8-13**, there is provided a product diverter **72** which is mounted to or depends from the cathode support **70**, the product diverter **72** having a frustoconical portion **73** and a vertical flange portion **74** which may be mounted, as illustrated in **FIGS. 12 and 13** to the outer cathode **60** and/or the cathode support **70**. As is known, the product diverter **72** would be electrically insulated from the cathodes **60** and **65** in order to prevent a product from being deposited thereon during the electro refining process. The frustoconical portion **73** of the product diverter **72** is reinforced by a plurality of circumferentially spaced apart struts **76** which may be welded or otherwise fixed to either or both of the inner vessel bottom **22** and the cylindrical wall **21**. As best seen in **FIG. 10**, the product diverter **72** may also include a cylindrical pan **77** in addition to or in lieu of the bottom **22** of the crucible or inner vessel **20**.

[0036] Ring structure **78** is internal of the vertical flange **74** and may provide support for a plurality of blade shaped sweepers **79** which may be rotatable independent of the product collector **80** which is a cylindrical container having wall **81** and a bottom **82**. A handle **83** extends vertically upwardly through the product collector **80** and preferably is aligned with the longitudinal axis of the PCR **10**.

[0037] The materials from which the PCR **10** is made are well known in the art and may include any suitable metal for the inner container or crucible **20** and the outer vessel **11**, representative metals being steel, stainless steel, Inconel or other well known metals in the nuclear electrorefining art. Similarly, insulation between the various metal components of the PCR **10** are also well known and are art recognized. Although there is shown in the above figures two cathodes **60** and **65** and a plurality of circumferentially spaced anode baskets **55** between the two cathodes, it should be understood that a larger plurality of concentric cathodes and concentric anode baskets may be employed as illustrated in the prior art shown in **FIG. 1**, wherein four cathode tubes form three channels within which the anode baskets rotate. A similar configuration may be used in the present invention with rotational driving mechanism being located exterior to the outermost cathode thereby freeing the center of the PCR **10** for removal of the product collector **80** axially of the vessels.

[0038] As is well known in the art, electrical power supplies are available and when a current flows between the anode baskets **55** and the cathodes **60** and **65**, uranium values in the anode baskets are transferred through the molten salt electrolyte which contains uranium cations and plate out on the cathode as uranium metal by reduction at the cathode. During operation of the Mark V electrorefiner, dense uranium dendrites build-up on the cathodes requiring scrapers as illustrated in the present invention to remove the uranium on the cathode; however, the dense inner coating often cannot be scraped and can only be removed by reversing the current flow so that uranium metal plated onto the cathodes is dissolved in the electrolyte and plates on the outside of the anode basket. The present invention significantly reduces this problem by providing a plurality of axially extending metal mandrel rods **50** which may be of

any suitable metal from the anodes but electrically connected to said cathodes **60**, **65** by an independent power supply so that during current reversal onto uranium metal plates onto the rods **50**. Accordingly, uranium metal when dissolved from the cathodes **60**, **65** will plate onto the mandrels **50** in lieu of the anode baskets **55**. This is important because the uranium values which plate on the rods **50** reduce or eliminate the amount of uranium metal plating on the anode baskets **55** during current reversal. Because in the Mark V electrorefiner, uranium metal plates onto the outside of the anode baskets during current reversal, when the current is again reversed, the uranium metal on the outside of the baskets must be removed first prior to any uranium values inside the baskets being transported via the electrolyte to the cathodes.

[0039] As seen in Tables 1 and 2, calculations show a significantly improved transfer rate throughput for the PCR electrorefiner of the present invention. While the Marl V electrorefiner has demonstrated a 150 kg/mo throughput, the PCR of the present invention is calculated to be able to move 450 kg/mo. for a second channel refiner and 840 l/mo or a two channel electrorefiner and this is a significant advantage over the current state of the art.

[0040] In other respects, operation of the current PCR electrorefiner **10** and the Mark V are similar. Both use the same materials of construction, the same anode and cathode materials, the same electrolytes and operating cycles. The PCR **10** of the present invention provides faster throughput, easier handling and less down time and maintenance, although requiring an extra power supply to the mandrels or rod **50** connected to the cathodes **60**, **65**.

[0041] While particular embodiments of the present invention have been shown and described, it will be appreciated by those skilled in the art that changes, modifications and improvements may be made, for example in the processing of the materials or in the electrode and/or cell design without departing from the true spirit and scope of the invention.

The embodiments of the invention in which an exclusive property or privilege is claimed are defined as follows:

1. A nuclear fuel electrorefiner for recovering uranium from nuclear material containing uranium, comprising a cylindrical vessel having a longitudinal axis containing at the bottom thereof a product collector movable axially of said cylindrical vessel, at least one cathode generally circular in horizontal cross section extending axially of and radially spaced inwardly of said vessel, a plurality of generally polyhedron-shaped anode baskets extending axially of said vessel, each anode basket having at least one face aligned with a radius of said vessel and circumferentially spaced from adjacent anode baskets and concentric with respect to said cathode, mechanism outside of said vessel rotating said generally polyhedron-shaped anode baskets with respect to said cathode, and an electrical power supply in selective electrical communication with said cathode and said anode baskets for causing uranium values in said anode baskets in the presence of a molten electrolyte containing uranium cations to move between said anode baskets and said cathode where uranium values are reduced to uranium metal and thereafter uranium metal is transported from said

cathode to said product collector axially removable from said vessel without removing either said anode baskets or said cathode.

2. The nuclear fuel electrorefiner of claim 1, wherein said cathode is a metal conductor.

3. The nuclear fuel electrorefiner of claim 1, wherein said cathode is steel.

4. The nuclear fuel electrorefiner of claim 1, wherein said cathode is steel coated with tungsten.

5. The nuclear fuel electrorefiner of claim 1, wherein said anode baskets have perforated faces.

6. The nuclear fuel electrorefiner of claim 1, wherein said anode baskets are generally hexahedron shaped having four axially extending faces.

7. The nuclear fuel electrorefiner of claim 6, wherein each anode basket has two axially extending faces aligned with a radius of said vessel and are longer in horizontal cross section than the other two axially extending faces.

8. The nuclear fuel electrorefiner of claim 1, wherein said anode baskets are generally pentahedron-shaped.

9. The nuclear fuel electrorefiner of claim 1, wherein said anode baskets rotate with respect to said cathode and said product collector.

10. The nuclear fuel electrorefiner of claim 1, wherein there is more than one cathode.

11. The nuclear fuel electrorefiner of claim 1, wherein there are a plurality of concentrically positioned cathodes and anode baskets.

12. The nuclear electrorefiner of claim 1, wherein there is at least one cathode exterior to each anode basket.

13. The nuclear electrorefiner of claim 1, wherein said anode baskets during rotation scrape at least some of the uranium metal deposited on an adjacent cathode to enhance transportation of uranium metal from said adjacent cathode to said product collector.

14. The nuclear electrorefiner of claim 1, and further comprising a product diverter positioned below said cathode sloping toward said product collector to direct uranium metal from said cathode to said product collector.

15. The nuclear electrorefiner of claim 14, wherein at least a portion of said product diverter is frustum shaped.

16. The nuclear electrorefiner of claim 15, and further including a scraper rotatable with said anode baskets for scraping uranium metal from said cathode and/or said product diverter.

17. A nuclear fuel electrorefiner for recovering uranium from nuclear material containing uranium, comprising a cylindrical vessel having a longitudinal axis containing at the bottom thereof a product collector movable axially of said cylindrical vessel, at least one cathode generally circular in horizontal cross section extending axially of and radially spaced inwardly of said vessel, a plurality of generally polyhedron-shaped anode baskets extending axially of said vessel, each anode basket having at least one face aligned with a radius of said vessel and circumferentially spaced from adjacent anode baskets and concentric with respect to said cathode, a plurality of axially extending metal rods spaced circumferentially about said longitudinal axis electrically insulated from and between at least some of said polyhedron-shaped anode baskets, mechanism outside of said vessel rotating said generally polyhedron-shaped anode baskets and said metal rods with respect to said cathode, and an electrical power supply in selective electrical communication with said cathode and said anode baskets and said

metal rods and when current flow is in a first direction uranium values in said anode baskets in the presence of a molten electrolyte containing uranium cations move between said anode baskets and said cathode where uranium values are reduced to uranium metal and when current is flowing reversely to the first direction uranium metal is transported from said cathode to said axially extending metal rods and when current again flows in the first direction uranium values are all transported from said anode baskets and said metal rods to said cathode and to said product collector axially removable from said vessel without removing either said anode baskets or said metal rods or said cathode.

18. The nuclear electrorefiner of claim 17, wherein each of said anode baskets is generally hexahedron shaped having four axially extending faces, two of said faces being generally aligned with a radius of said vessel and longer in horizontal cross section than the other two axially extending faces.

19. The nuclear electrorefiner of claim 18, wherein said axially extending anode baskets have the longer faces thereof perforated.

20. The nuclear electrorefiner of claim 19, wherein at least one axially extending metal rod is positioned between adjacent anode baskets.

21. The nuclear electrorefiner of claim 20, wherein said anode baskets are carried by an annular plate extending inwardly from said vessel and said metal rods extend through said plate.

22. The nuclear electrorefiner of claim 21, wherein there are a plurality of concentric cathodes, each substantially circular in horizontal cross section.

23. The nuclear electrorefiner of claim 22, wherein anode baskets are intermediate adjacent cathodes.

24. The nuclear electrorefiner of claim 23, wherein said anode baskets during rotation scrape at least some of the uranium metal deposited on an adjacent cathode to enhance transportation of uranium metal from said adjacent cathode to said product collector.

25. The nuclear electrorefiner of claim 24, and further comprising a product diverter positioned below said cathode sloping toward said product collector to direct uranium metal from said cathode to said product collector.

26. The nuclear electrorefiner of claim 25, wherein at least a portion of said product diverter is frustum shaped.

27. The nuclear electrorefiner of claim 26, and further including a scraper rotatable with respect to said cathode for scraping uranium metal from said cathode and/or said product diverter.

28. A nuclear fuel electrorefiner for recovering uranium from nuclear material containing uranium, comprising a cylindrical vessel having a longitudinal axis containing at the bottom thereof a product collector movable axially of said cylindrical vessel, a plurality of concentric radially spaced apart cathodes generally circular in horizontal cross

section extending axially of said vessel, a plurality of generally polyhedron-shaped anode baskets extending axially of said vessel, each anode basket having at least one face aligned with a radius of said vessel and circumferentially spaced from adjacent anode baskets and concentric with respect to said cathodes, a plurality of axially extending metal rods spaced circumferentially about said longitudinal axis electrically insulated from and between at least some of said polyhedron-shaped anode baskets, mechanism outside of said vessel rotating said generally polyhedron-shaped anode baskets and said metal rods with respect to said cathodes, and an electrical power supply in selective electrical communication with said cathodes and said anode baskets and said metal rods and when current flow is in a first direction uranium values in said anode baskets in the presence of a molten electrolyte containing uranium cations move between said anode baskets and said cathodes where uranium values are reduced to uranium metal and when current is flowing reversely to the first direction uranium metal is transported from said cathodes to said axially extending metal rods and when current again flows in the first direction uranium values are simultaneously transported from said anode baskets and said metal rods to said cathodes and said product collector axially removable from said vessel without removing either said anode baskets or said metal rods or said cathodes.

29. The nuclear fuel electrorefiner of claim 28, wherein said anode baskets are generally hexahedron shaped having four axially extending faces at least two of which are perforated.

30. The nuclear fuel electrorefiner of claim 29, wherein each anode basket has two perforated axially extending faces generally aligned with a radius of said vessel and are longer in horizontal cross section than the other two axially extending faces.

31. The nuclear fuel electrorefiner of claim 30, wherein an axially extending metal rod is positioned between each anode basket and the adjacent anode basket.

32. The nuclear electrorefiner of claim 31, and further comprising a product diverter positioned below said cathodes sloping toward said product collector to direct uranium metal from said cathodes to said product collector.

33. The nuclear electrorefiner of claim 32, wherein at least a portion of said product diverter is frustum shaped.

34. The nuclear electrorefiner of claim 33, and further including a scraper rotatable with said anode baskets for scraping uranium metal from said cathodes and/or said product diverter.

35. The nuclear electrorefiner of claim 28, wherein there are independent electrical power supplies between said cathodes and said anode baskets and between said cathodes and said metal rods.

* * * * *